

INSTALLATION INSTRUCTIONS | 4-Inch LED Shallow Downlights: R4SIC Insulated Ceiling (IC)/StopAire™ Series

Note: Before attempting installation please refer to your local electrical code.

IMPORTANT SAFETY INSTRUCTIONS:

- Read Instructions before installation; save Instructions for later use.
- Product should be installed by a Qualified Electrician.
- All electrical connections must be in accordance with local and National Electrical Code (NEC) standards. If you are unfamiliar with proper electrical wiring connections, obtain the services of a qualified electrician.
- Before starting the installation, disconnect the power by turning off the circuit breaker or by removing the appropriate fuse at the fuse box. Turning the power off at the light switch is not sufficient to prevent electrical shock.
- Product must be grounded to avoid potential electric shock and any other potential hazards.
- Product must be mounted in locations and at heights and in a manner consistent with its intended use, and in compliance with National Electrical Code and local codes. Use of accessory equipment is not recommended.
- Do not mount near gas or electric heaters.
- Equipment should be mounted in locations and at heights where it will not readily be subject to tampering by unauthorized personnel.
- **WARNING: RISK OF SHOCK**
 - Turn off the power at fuse or circuit breaker box before installation or maintenance work.
 - Wear rubber soled shoes and work on a sturdy wooden or non-conductive ladder.
 - Ground the fixture to avoid potential electric shocks and to ensure reliable starting.
 - Double check all connections, making sure they are tight and correct.
- **WARNING: RISK OF FIRE**
 - Most dwellings built before 1985 have supply wire rated at 60°C
 - Supply conductors (power wires) connecting the fixture must be rated at minimum of 90°C
 - Consult a qualified electrician before installation
- Installing contrary to instructions may cause unsafe conditions.
- If the product has any visible damage do not install it.
- Avoid hazards to children: account for all parts and properly dispose of all packing materials.
- Call the Technical Support department at ConTech Lighting with any installation questions: 847.559.5500.
- **WARRANTY**
 - ENERGY STAR® Products are covered for three (3) years by a full replacement guarantee after date of installation. In addition, ConTech LED products carry a five (5) year limited warranty from date of purchase.

INSTALLATION

FIGURE 1

- Housing can be installed in direct contact with insulation

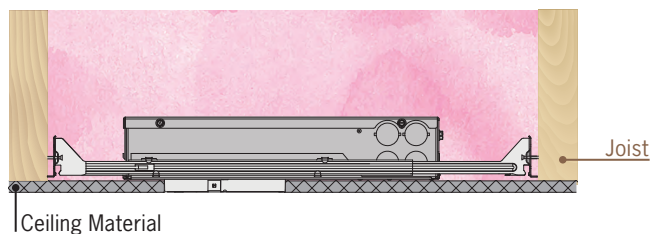
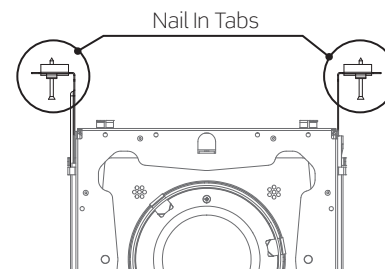

FIGURE 2

- Install Hanger Bars to fixture; ensure End Tabs are facing outward



- Extend Hanger Bars to fit between joists
- Position housing by hammering nail on bars into Joists
- Hangers should be level with bottom of the Joists
- Use T-Bar Slot in the bottom bars for suspended (T-Bar) ceilings, bending the tabs to hold T-Bar tightly
- Make all necessary electrical connections (See “Electrical Connection” section of this instruction sheet)

CONTINUED

INSTALLATION INSTRUCTIONS | 4-Inch LED Shallow Downlights: R4SIC Insulated Ceiling (IC)/StopAire™ Series

Note: Before attempting installation please refer to your local electrical code.

ELECTRICAL CONNECTION

Local electrical codes should be consulted to determine acceptable installation: Conduit, Romex or Flexible Metal Cable

- Remove the Junction Box cover
- Follow the proper wiring diagram for the selected electrical/dimming option
- Ensure wiring is the correct voltage for the fixture – either 120V, 277V or 347V
- Close Junction Box cover after wiring; ensure all wires are safely within Junction Box before closing

WIRING DIAGRAM 1

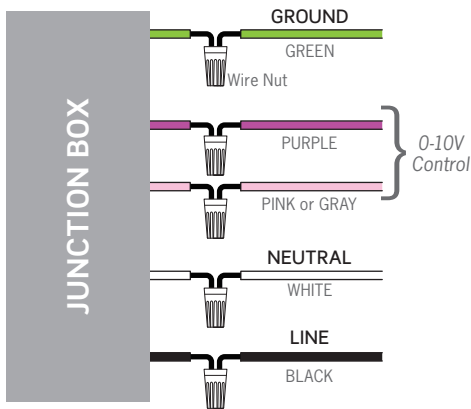

DIMMING OPTIONS: MVD, 34D2, MVD6, MVD8

ELECTRICAL: 120V, 277V or 347V

DIMMING: TRIAC, ELV and 0-10V

- TRIAC or ELV Dimming requires Purple and Pink/Gray wires to be capped
- When dimming with 0-10V, Class 1 wiring (300V wiring inside conduit) is required; consult factory for additional details

WIRING DIAGRAM 2

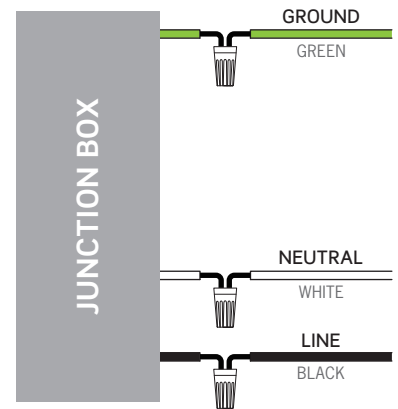

DIMMING OPTIONS: 12D3

ELECTRICAL: 120V Only

DIMMING: Lutron Hi-lume

WIRING DIAGRAM 3

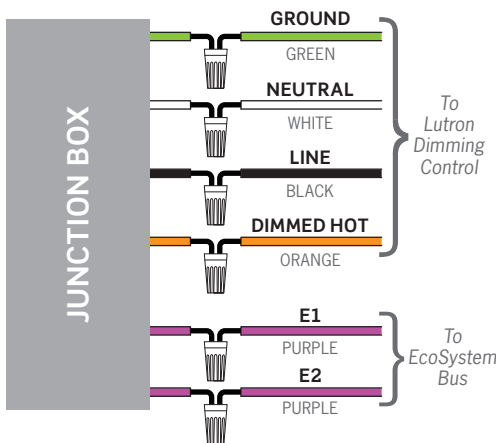

DIMMING OPTIONS: MVD4

ELECTRICAL: 120V or 277V

DIMMING: Lutron EcoSystem

WIRING DIAGRAM 4

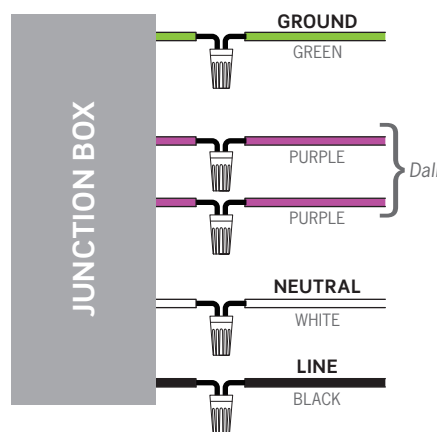

DIMMING OPTIONS: MVD7, MVD9

ELECTRICAL: 120V or 277V

DIMMING: Dali

WIRING DIAGRAM 5

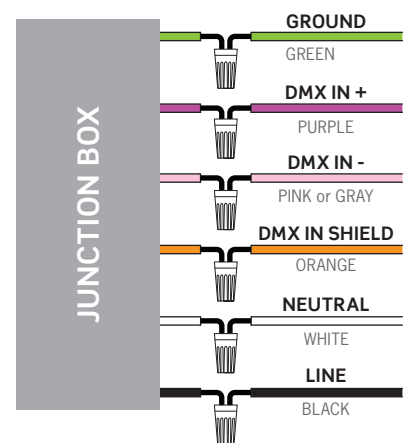

DIMMING OPTIONS: MVDMX

ELECTRICAL: 120V or 277V

DIMMING: DMX

CONTINUED

INSTALLATION INSTRUCTIONS | 4-Inch LED Shallow Downlights: R4SIC Insulated Ceiling (IC)/StopAire™ Series

Note: Before attempting installation please refer to your local electrical code.

TRIM AND LED MODULE INSTALLATION:

FIGURE 3

- Remove protective cover from LED Module
- Attach Reflector to Module by carefully inserting into Module collar
- Friction Clips secure Trim Assembly in Module
- Make the LED Module electrical connection

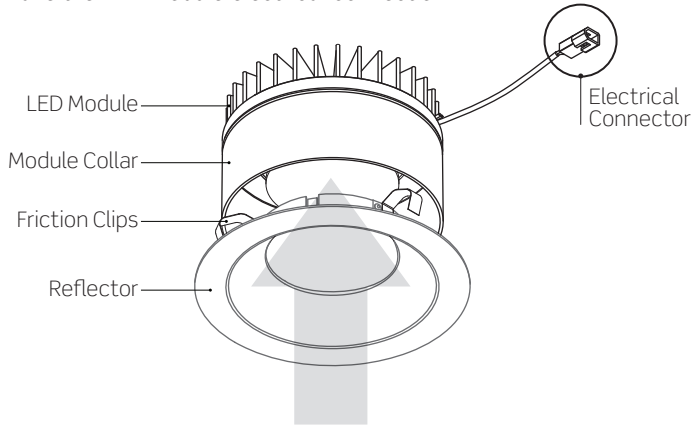
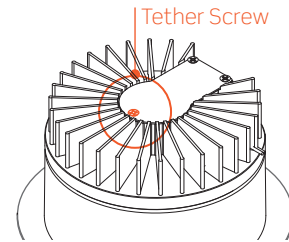
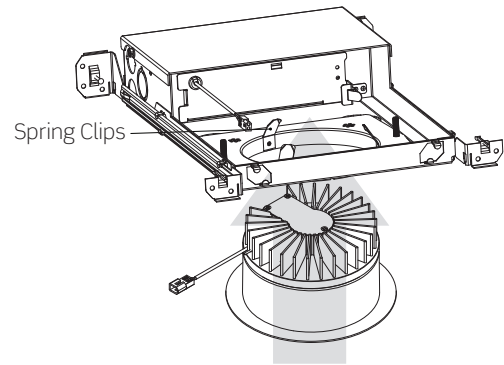

FIGURE 4

- If required by code, connect Tether to Screw on top of Module



- Push LED Module with assembled Reflector through the hole in Mounting Frame until flush with ceiling
- Module is held securely in place with Spring Clips located on Housing Frame



TRIMLESS INSTALLATION: MUD FRAME, TRIM AND LED MODULE

FIGURE 6

- Once Gypsum/Wall Board ceiling has been installed, the Mud Frame can be installed
- **NOTE:** The deep side of the Mud Frame Collar gets inserted up into the housing, so the shallow side is room facing
- Align notches in Mud Frame with notches in Housing Mounting Frame to align holes in Mud Frame with hole patterns in Mounting Frame
- Secure Mud Frame to ceiling and housing with four (4) provided self-drilling screws
- Joint compound can now be applied to ceiling and Mud Frame

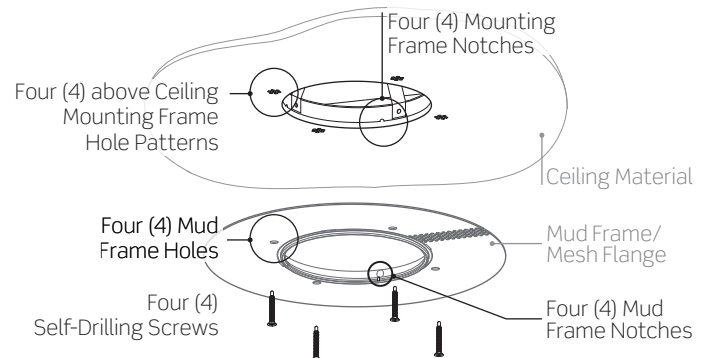
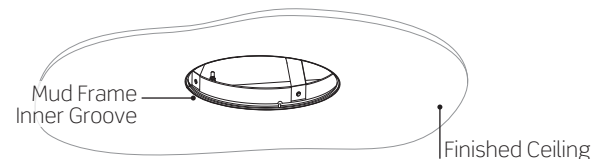

FIGURE 7

- After finish coat paint has been applied to ceiling, ensure inner groove in Mud Frame is clear from excess joint compound and paint so reflector will seat properly
- Install LED Module following instructions on previous page then make electrical connections



INSTALLATION INSTRUCTIONS | 4-Inch LED Shallow Downlights: R4SIC Insulated Ceiling (IC)/StopAire™ Series

Note: Before attempting installation please refer to your local electrical code.

OPTIC REMOVAL/SWAP:

FIGURE 8

- Pull down to remove both the Trim and LED Module from the ceiling; disconnect the low voltage harness
- Remove Trim from LED Module
- Twist Optic **counter clockwise** and pull to remove
- Align slots in new Optic with Retaining Tabs on LED Holder, pushing new Optic to snap into place
- Reinstall Trim to LED Module by carefully inserting into collar of Module; friction clips secure trim assembly in Module
- Make the Module electrical connection
- Push Module with assembled Trim through the aperture in the mounting frame until flush with ceiling; Module is held securely in place with Spring Clips located on Housing Mounting Frame

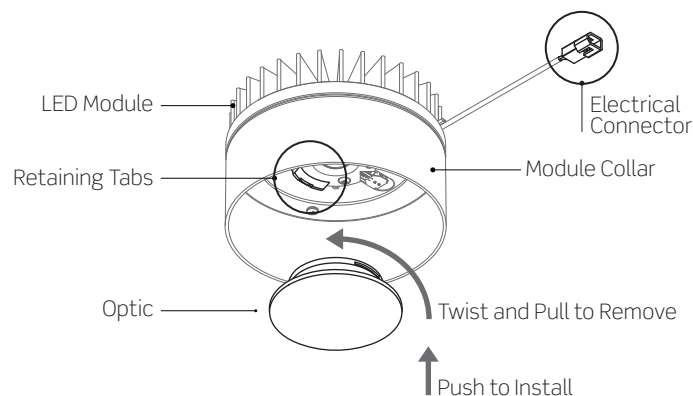

REPLACEMENT OF LED DRIVER:

LED Driver should be replaced by a qualified electrician.
Turn off power at fuse or circuit breaker box before replacing the LED Driver.

FIGURE 9

- Pull and drop the Trim and LED Module from the Frame
- Disconnect the electrical connection
- Remove the Junction Box Cover with LED Driver attached to it by releasing Retention Spring on top of Junction Box
- Disconnect Driver from line voltage input wiring in Junction Box
- Disconnect the Driver from the LED Leads; Leads are terminated by Twist-On Connectors
- Reinstall Factory Approved LED Driver by reversing this procedure

