

**Wall Mount (Up, Down, or Up/Down)  
INSTALLATION INSTRUCTIONS**

Before attempting installation please refer to your local electrical code.

Fixture is designed to mount flush to wall surface.

1. Detach the wall mounting bracket from the back of fixture by removing screw (Fig. 1).
2. Determine proper orientation for the wall mounting bracket according to markings on bracket.
3. Mount the bracket and junction box accessory plate (provided) if necessary per Figure 2.
4. Attach tether between fixture and wall mounting bracket to aide in wiring.
5. Follow the wiring diagram from Figure 3 for the appropriate electrical/dimming option.
6. Carefully feed any excess wire into junction box to avoid pinching wires.
7. Reattach cylinder to mounting bracket and secure in place with screw from step 1.
8. For fixtures rated and installed in wet location: apply an outdoor rated caulk between the wall and fixture to ensure water tight seal.

**IMPORTANT SAFETY INSTRUCTIONS:**

- Read all the instructions before installation. Save instructions for later use.
- Turn off power at fuse or circuit breaker box before installation or before doing any maintenance work.
- Product must be grounded to avoid potential electric shock and any other potential hazards.
- Product must be mounted in locations and at heights and in a manner consistent with its intended use, and in compliance with National Electrical Code and local codes. Use of accessory equipment is not recommended.
- Installing contrary to instructions may cause unsafe conditions.
- Do not block light from the trim aperture, in whole or in part, as this may cause unsafe conditions.
- Warning: Risk of fire. Most dwellings built before 1985 have supply wire rated at 60°C. Consult a qualified electrician before installation.
- Avoid hazards to children: account for all parts and properly dispose of all packing materials.
- Call the Technical Support department at ConTech Lighting with any installation questions: 847.559.5500.

**WARRANTY:**

- Energy Star products are covered for three (3) years by a full replacement guarantee after date of installation. In addition, ConTech LED products carry a five (5) year limited warranty from date of purchase. The Up/Down Wall Mount Fixture is not Energy Star Listed.

**1**

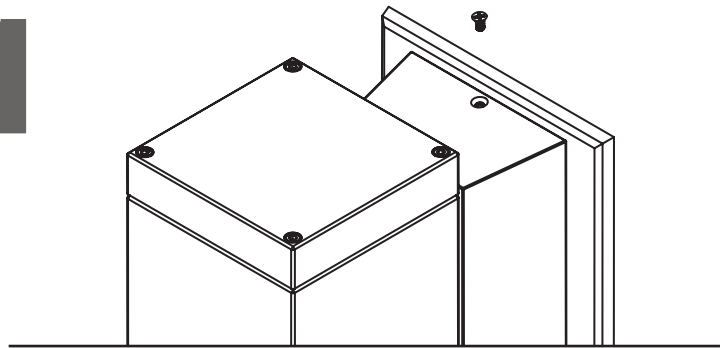

**2**

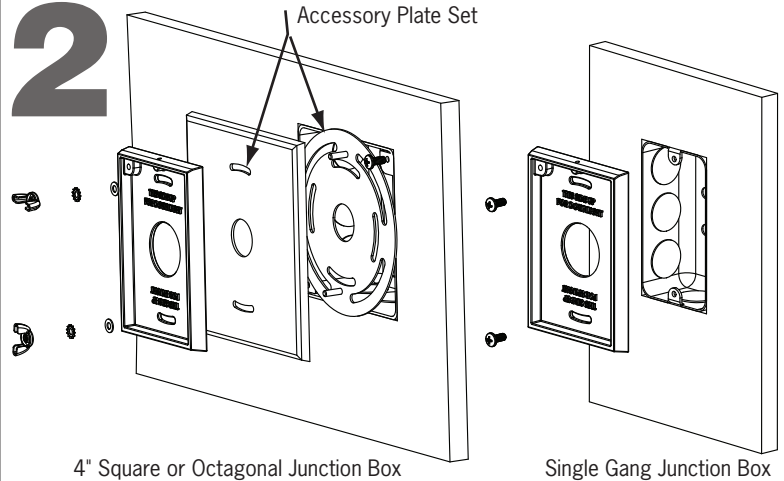

**3**

120V Triac/ELV Dimming (12D1)

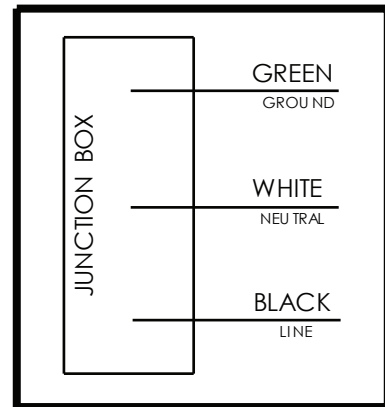

120-277V 0-10V Dimming (MVD2)

